

SEE DISTRICT STANDARDS FOR WATER SERVICE METER BOX REQUIREMENTS

FOR AREAS SUBJECT TO VEHICULAR TRAFFIC, USE PRECAST CONCRETE VAULT 3'-8"x2'-8"x3'-6" UTILITY VAULT CO. MODEL 233-LA WITH NO. 23-233P DIAMOND PLATE COVER OR EQUAL. FOR NON-TRAFFIC AREAS USE CARSON PLASTIC VAULT NO. 1730 OR EQUAL 1'-6"x2'-1"x3'-2"

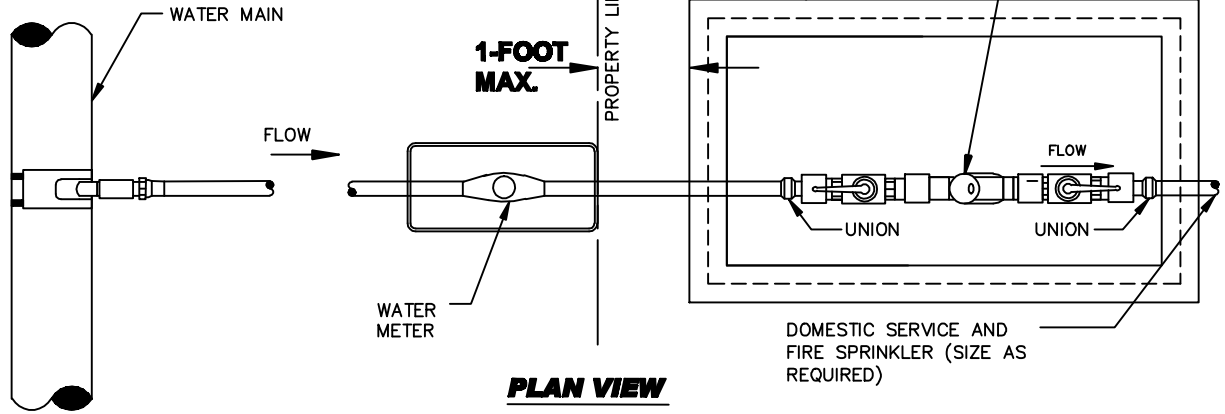

PLAN VIEW
NOT TO SCALE

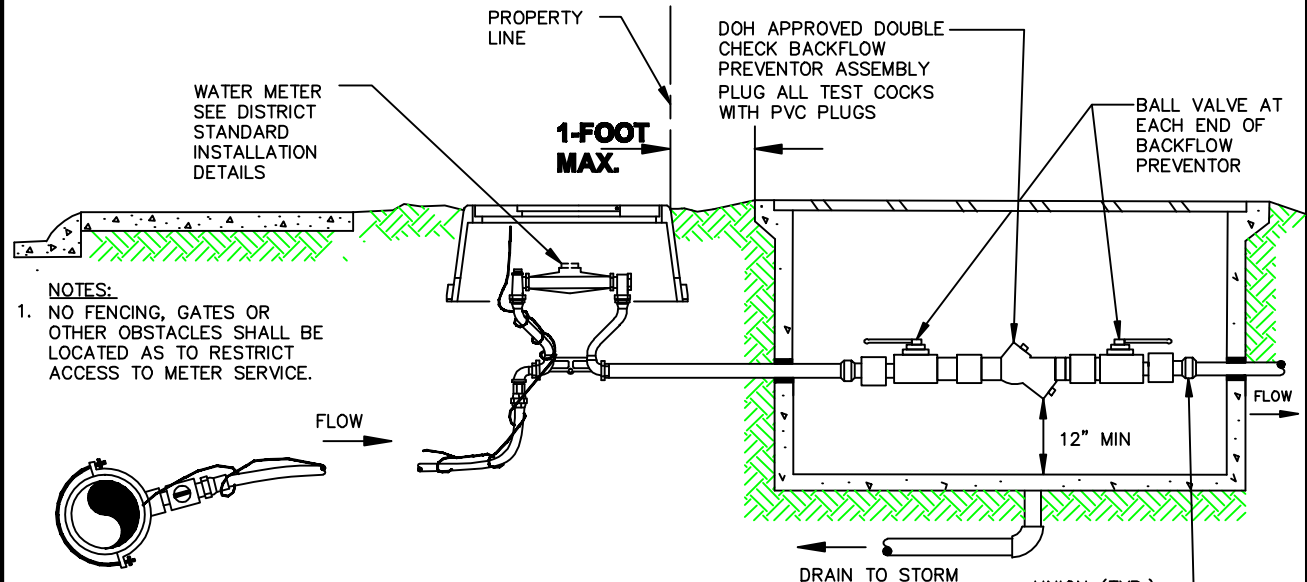

- NOTES:**
1. NO FENCING, GATES OR OTHER OBSTACLES SHALL BE LOCATED AS TO RESTRICT ACCESS TO METER SERVICE.

PROFILE VIEW
NOT TO SCALE

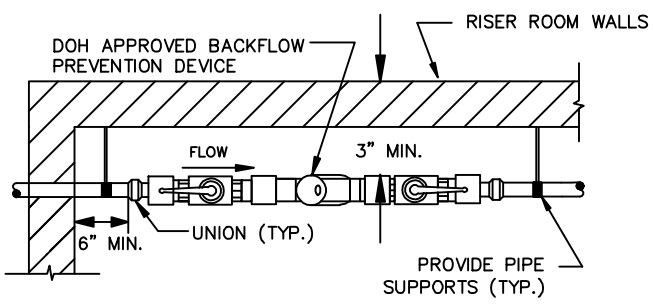

PLAN VIEW
NOT TO SCALE

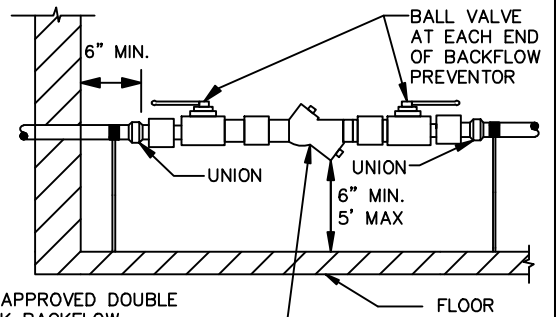

DOH APPROVED DOUBLE CHECK BACKFLOW PREVENTOR ASSEMBLY
PLUG ALL TEST COCKS WITH PVC PLUGS

PROFILE VIEW
NOT TO SCALE

ALTERNATE / ADDITIONAL DCVA IN RISER ROOM DETAIL

STANDARD FIRE SPRINKLER DCVA CONNECTION DETAIL

REV. 07/23/2008